

The Parkland range was first designed by UAP for the redeveloped Roma Street Parkland in inner city Brisbane, Australia. Characterised by clean lines, robust form and weathered steel, the range is designed to integrate with both urban and natural environments.

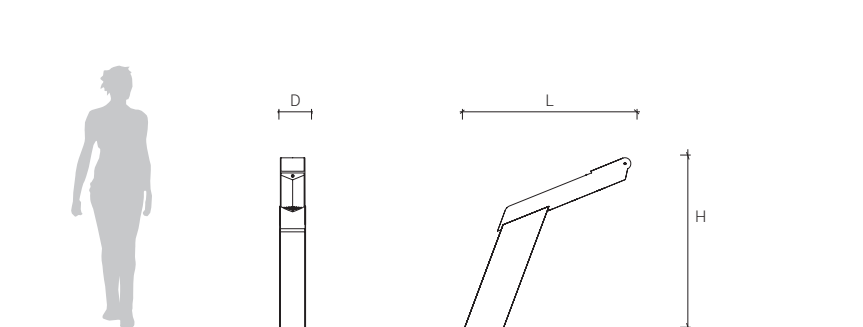

PRODUCT CODE	DESCRIPTION	L (mm)	D (mm)	H (mm)
PRK06-A-MS-W-T	Parkland DRINKING FOUNTAIN / mild steel weathered frame / mild steel powder coated top	1075	170	1110
PRK06-A-MS-W-SS-E	Parkland DRINKING FOUNTAIN / mild steel weathered frame / stainless steel electro polished top	1075	170	1110



## MATERIALS

FRAME	Mild steel (galvanised) Mild steel (weathered) Mild steel (powder coated)
BOWL	Mild steel (powder coated) Stainless steel (electro polished)
FIXINGS	4 x M12 bolts (cast-in hold down bolts, Dynabolts or chemical anchors)

## ADDITIONAL INFORMATION

AVAILABILITY	Not yet available in the US
WARRANTY	See UAP Warranty Information
MAINTENANCE	See UAP Maintenance Information

## CONTACT

For more information and for pricing, email [supply@uapcompany.com](mailto:supply@uapcompany.com) or call +1 212 727 2819 for US or +61 7 3630 6300 for Australia.

